

INSTALLATION CERTIFICATE

The undersigned qualified installer attests to have personally fitted the here described system following the manufacturer instructions.

By :

Sold on :

Type of product : 818H

Vehicle :

GEMINI Technologies S.p.A.
Via Luigi Galvani 12 - 21020 Bodio Lomnago (VA) - Italia
Tel. +39 0332 943211 - Fax +39 0332 948080
Web site: www.gemini-alarm.com



KIT Parking Sensor 818H

INSTALLATION AND USE MANUAL



AC 2878/UK Rev. 00 - 02/12

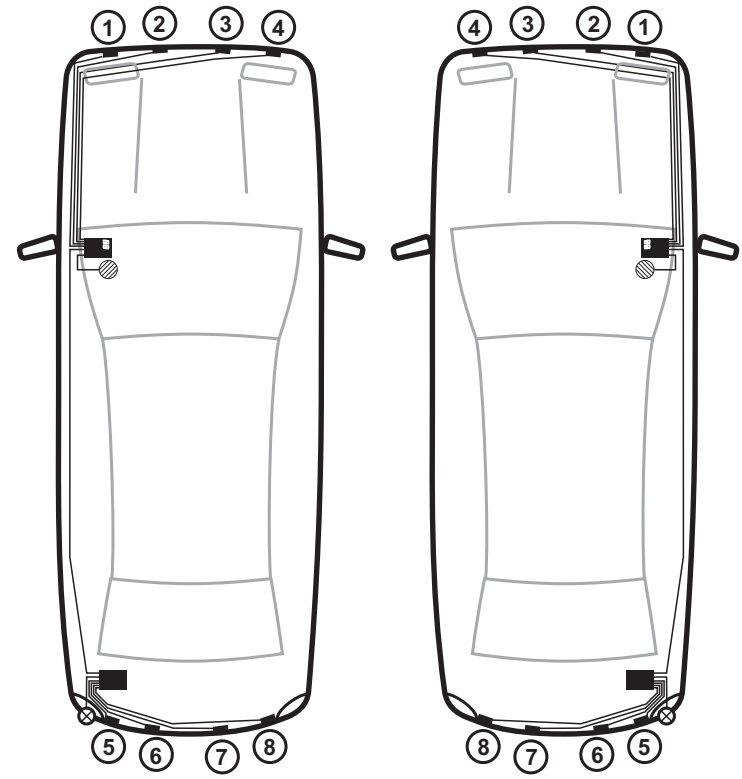
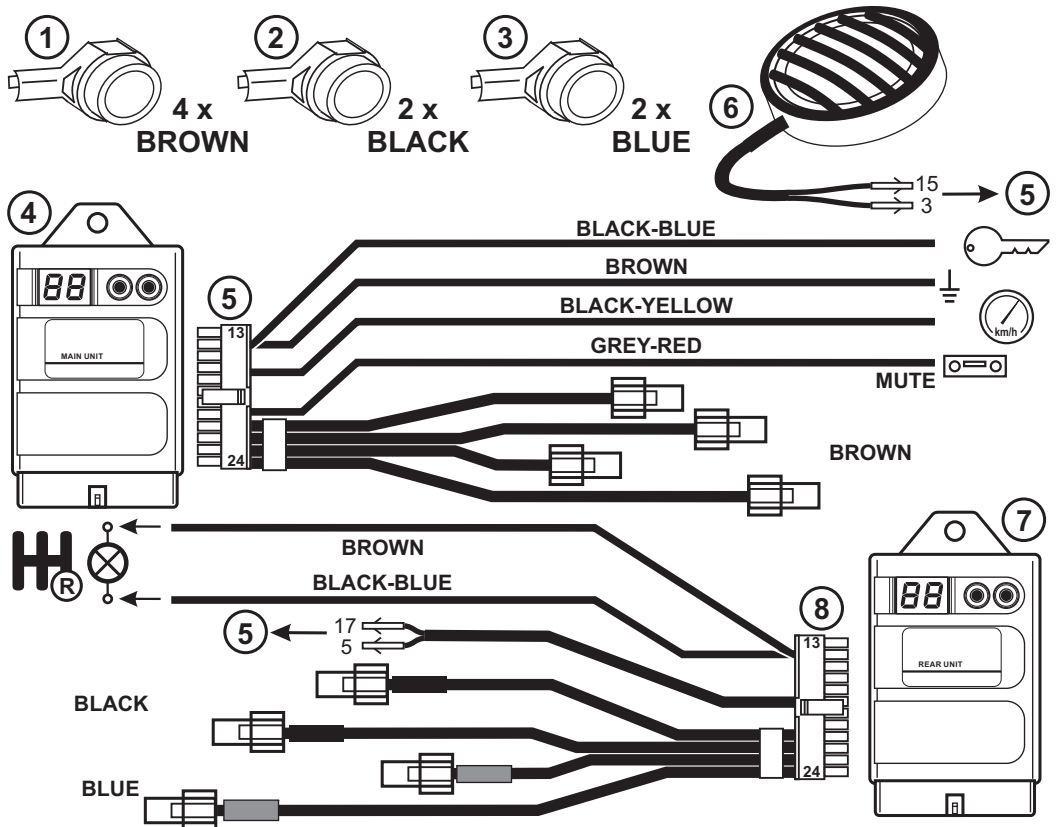

Sensor 1: front with shortest cable.
Sensor 4: front with longest cable.

Sensor 5: rear with shortest cable.
Sensor 8: rear with longest cable.

TECHNICAL SPECIFICATIONS

Supply voltage	From 9 to 30 Vdc
Current consumption when system running	350mA max.
Service temperature range	From -25°C to +70°C
Ultrasound frequency	40kHz

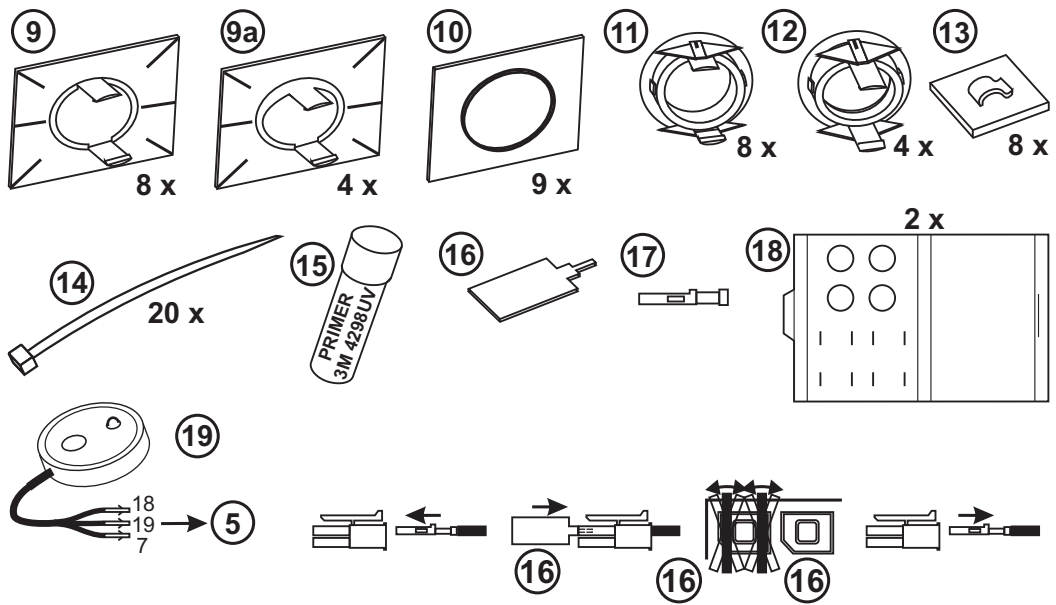

How to remove a terminal with the adequate tool (16).

1.0 - PRELIMINARY ADVICE..... PAGE 02

USER MANUAL

2.0 - DYSTEM OPERATION..... PAGE 03

 2.1 - Detection Zones..... PAGE 03

 2.2 - Rear sensors..... PAGE 03

 2.3 - Automatic activation of front sensors (odometer signal)..... PAGE 04

 2.4 - Timer-activated of front sensors (odometer not connected)..... PAGE 04

3.0 - TROUBLESHOOTING GUIDE..... PAGE 05

 3.1 - Low power supply signal..... PAGE 05

 3.2 - Faulty sensors..... PAGE 05

 3.3 - Others..... PAGE 05

4.0 - WARRANTY CONDITIONS..... PAGE 05

5.0 - WASTE ELECTRICAL AND ELECTRONIC EQUIPMENT (WEEE) DIRECTIVE..... PAGE 05

INSTALLER MANUAL

6.0 - INSTALLATION OF SENSORS..... PAGE 06

7.0 - CONNECTIONS..... PAGE 09

8.0 - PROGRAMMING..... PAGE 10

9.0 - SETTING OF PARAMETERS..... PAGE 11

 9.1 - Front unit (main unit)..... PAGE 11

 9.2 - Rear unit..... PAGE 11

1.0 - PRELIMINARY ADVICE

Dear customer,
 Before installing, identify your kit and refer to it for the correct instructions.
 The Caution and Warning signs in this manual provide important notices for installing and using this product.
 Be sure to follow them in order to ensure a safe and reliable use:

 **For the user.**
 This sign highlights useful information or indications regarding the use of the parking system.

 **For the installer.**
 This sign indicates various operating modes according to connections and programming of the system or it simply provides useful indications for the installation.

3.0 - SYSTEM OPERATION

 Remember to always look around the vehicle while parking.
 Small obstacles or objects with low reflectance might not be detected.

 The parking system is designed only as a parking aid, it should not be considered to replace care and attentiveness while manoeuvring.

2.1 - DETECTION ZONES

 Detection zones are indicated as “F” (front) and “R” (rear).
 Detection zones closest to the obstacle are indicated as “FC” (front) and “RC” (rear) and displayed as “STOP”.
 The STOP zone is the minimum distance detected between an obstacle and the sensor and in this case the warning tone is solid.

 The detection range and the volume of the buzzer can be adjusted (see “setting of parameters”) according to the needs of the user and the vehicle on which the system is installed.
 The stage-by-stage sound alert will vary according to the distance and the detection zone (front or rear).

 For the overall functionality of the system, check the programming of all the sensors, front and rear.

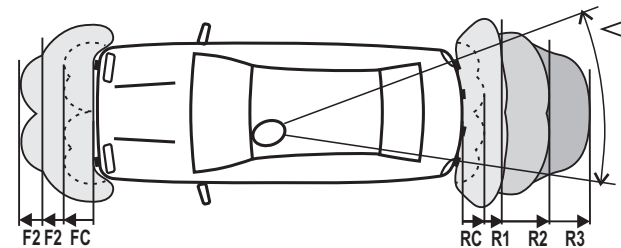

ZONE	DISTANCE
FC	35 cm
F1	55 cm
F2	80 cm

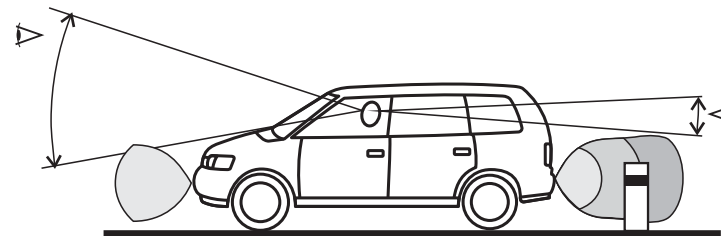

ZONE	DISTANCE
RC	35 cm
R1	55 cm
R2	115 cm
R3	160 cm

2.2 - REAR SENSORS

The rear sensors are activated when reverse gear is engaged; an audible signal warning will indicate the sensors are active.

Detection of obstacles is signalled by the buzzer and the tone of the buzzer indicates in which detection zone the obstacle is located.

The faster the beeping, the closer the obstacle; a continuous tone indicates the obstacle is extremely close to the bumper.

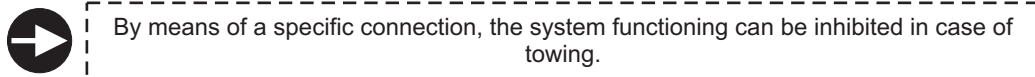

2.3 - AUTOMATIC ACTIVATION OF FRONT SENSORS (odometer signal)

When ignition is turned ON, the parking system becomes and stays active as long as the vehicle speed remains under approx. 15km/h (set odometer pulses according to vehicle, parameter 11).

At speeds above 15km/h, the front sensors are disabled and the LED turns off.

The LED turns ON to indicate that the sensors are activate and turns OFF when they are not in operation.

Press the button with the LED to deactivate the sensors (ex. when in queue).

The push-button can be:

- Short-pressed (about 1 sec.): sensors are deactivated until the button is pressed again. If the push-button is long pressed (when sensors are only temporarily deactivated) they will be completely disabled until ignition is turned ON again (ignition OFF-ON).
- Long-pressed (about 3 sec., you will hear a beep): sensors remain active until ignition is turned OFF and ON again.

2.4 - TIME-ACTIVATED OF FRONT SENSORS (odometer not connected)

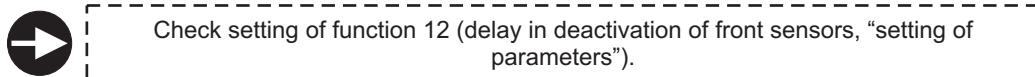

The front sensors can be activated by turning the ignition ON or by pressing the push-button with the LED.

Operation is directly related to the setting of the parameters.

To activate the sensors through the push-button, press it at the beginning of the manoeuvre; once you have parked, short press the push-button again to deactivate the sensors.

To deactivate the sensors totally, press and hold the button for at least 3 sec.; a beep confirms the operation. They will remain switched off until the engine is turned OFF and ON again.

By modifying the time setting of the front sensors (function 12, preset value "00"), the front sensors will work as follows:

- If, within the preset time, no obstacle is detected in front of the vehicle, the sensors will automatically be deactivated.
- If, within the preset time, the obstacle is still detected, the sensors will remain active as long as the obstacle is detected and will deactivate 3" after detecting the last obstacle.
- If you need to use the front sensors again after the automatic deactivation, simply press the push-button with the LED.
The sensors will automatically deactivate 3" after detecting the last obstacle.

3.0 - TROUBLESHOOTING GUIDE

3.1 - LOW POWER SUPPLY SIGNAL

If, when the control unit is turned on, the battery level is too low to guarantee the accuracy of the system, the buzzer will almost immediately give out a deep warning tone for 5".

This will inform the user that ALL the sensors are deactivated.

The driver will therefore know that he will have to do without the parking sensors.

3.2 - FAULTY SENSORS

If, when the control unit is turned on, one of the sensors turns out to be inoperative or not connected, an audio signal will sound for 3".

If more than one sensor is inoperative, the number of the faulty sensors will be alternatively displayed on the front unit (main unit).



Sensor 1
inoperative.



Sensor 6
inoperative.



One single faulty sensor alters the correct functioning of the whole parking system.

3.3 - OTHERS

POSSIBLE CAUSE	SOLUTION
Ice on sensors	Clean the sensors
Sensors mounted too low	Use the angle brackets (9a or 12) to tilt axe of sensors upwards
Back part of sensors in contact with frame	Create a separation between the sensors and the vehicle (at least 2mm)
Sensors detect external spare wheel	Modify the programming of parameter 10 (rear unit)

4.0 - WARRANTY CONDITIONS

This product is guaranteed to be free from defects in workmanship for a period of 24 months from the date of installation reported on this warranty, in compliance with the 1999/44/CE Warranty Directive (L. D. N° 24 of the 02/02/2002).

Please fill-in entirely the guarantee certificate included in this booklet and DO NOT REMOVE the guarantee label from the device.

The warranty will become void if labels are missing or torn, if the installation certificate is not fully compiled or if the enclosed sale document is missing.

The warranty is valid exclusively at authorized Gemini Technologies centers.

The manufacturer declines any responsibility for eventual malfunctions of the parking sensors or any damage to the vehicle electrical system due to improper installation, use or tampering.

The parking system is strictly a parking assist device, it should not be considered to be a safety device for any purpose.

5.0 - WASTE ELECTRICAL AND ELECTRONIC EQUIPMENT (WEEE) DIRECTIVE

The present device does not fall within the scope of Directive 2002/96/EC on Waste Electrical and Electronic Equipment (WEEE) as specified in art. 2.1 of L.D. no. 151 of 25/07/2005.

INSTALLER MANUAL

6.0 - INSTALLATION OF SENSORS

! To install the sensors on a metal bumper, you must use appropriate adapters (not supplied).

Choose the suitable type of plastic bracket and mark the center of the holes to drill. For brackets "9" drill holes with a 18mm diameter, for brackets "9a" drill holes with a 22mm diameter and for brackets "10" and "11" drill holes with a 24mm diameter. Sensors and plastic brackets can be painted to match the color of your bumpers.

- ① ② ③ + ⑨ → ∅ 18
- ② ③ + ⑨a → ∅ 22
- ① ② ③ + ⑪ ⑫ → ∅ 24

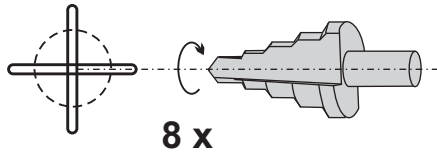

! Before drilling, inspect behind the bumper to check for any possible obstruction such as iron struts and, in any case, be careful to avoid damaging parts behind the bumper.

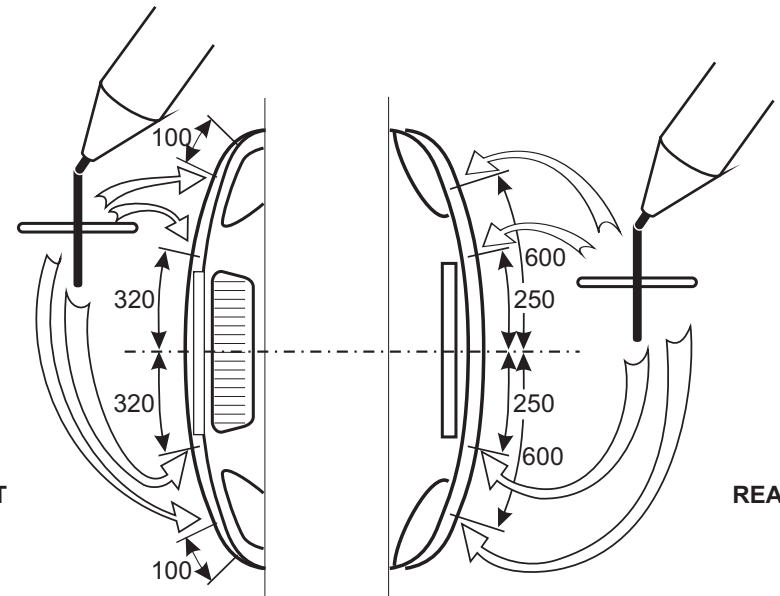
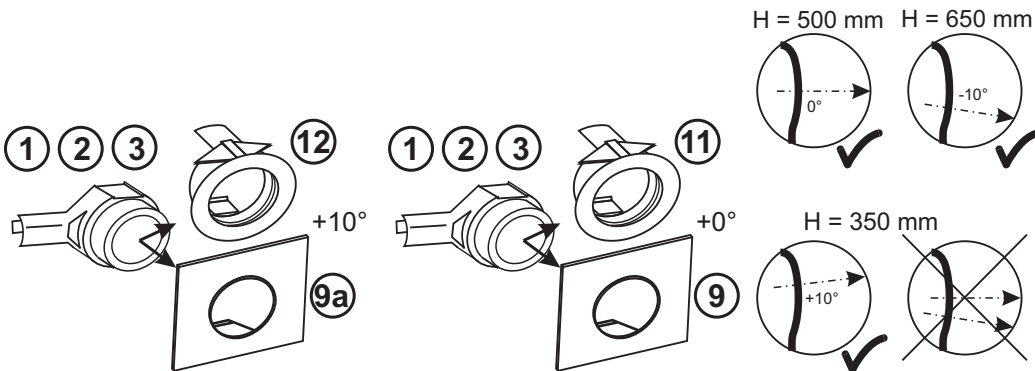
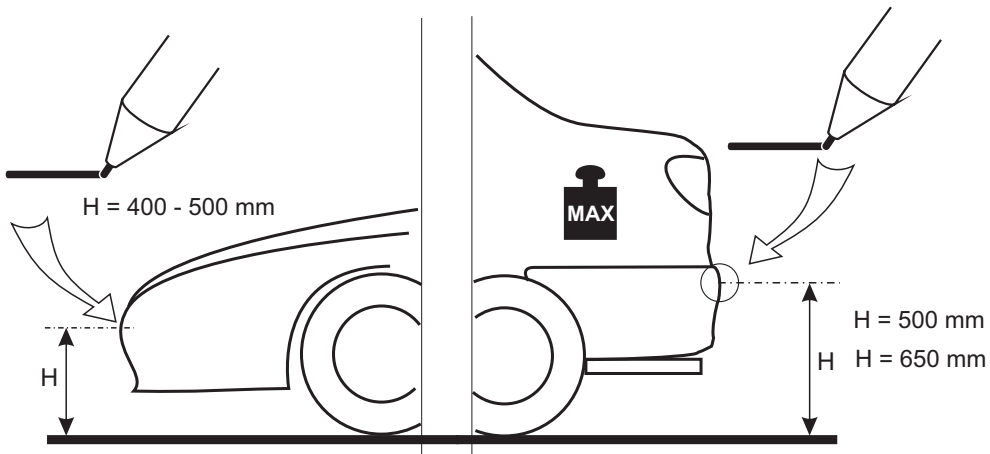

! Clean thoroughly the plastic brackets (9 or 9a) and around the holes, apply "PRIMER" (12), let dry for at least one minute and then proceed as follows.

Remove the protective film from the adhesive (10) and apply it to the bracket (9 or 9a) or proceed as indicated in the next page to snap the bracket in the hole from the outer part of the bumper. Position the plastic brackets so that the connector of the sensor comes out horizontally.

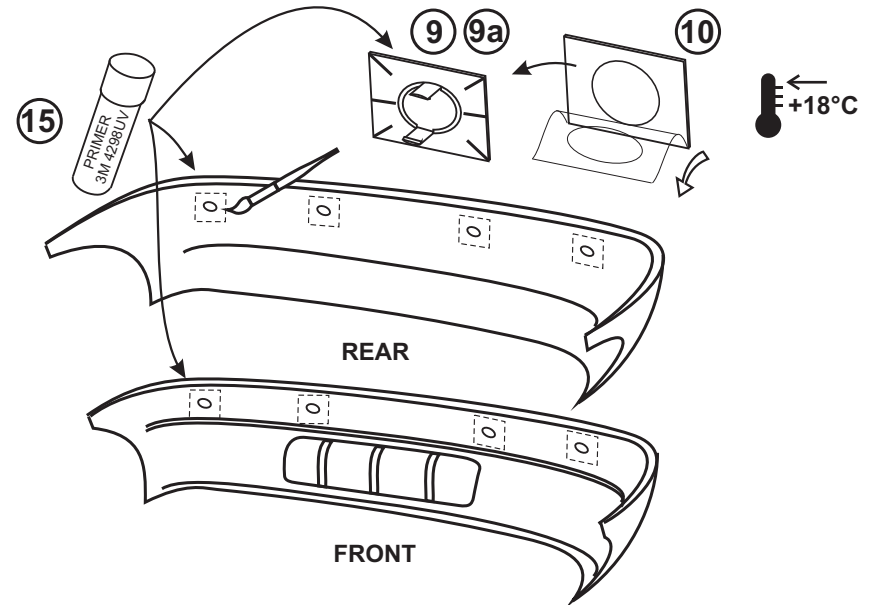

Snap the bracket (11 or 12) in the hole from the outer part of the bumper. Position the plastic brackets so that the connector of the sensor comes out horizontally.

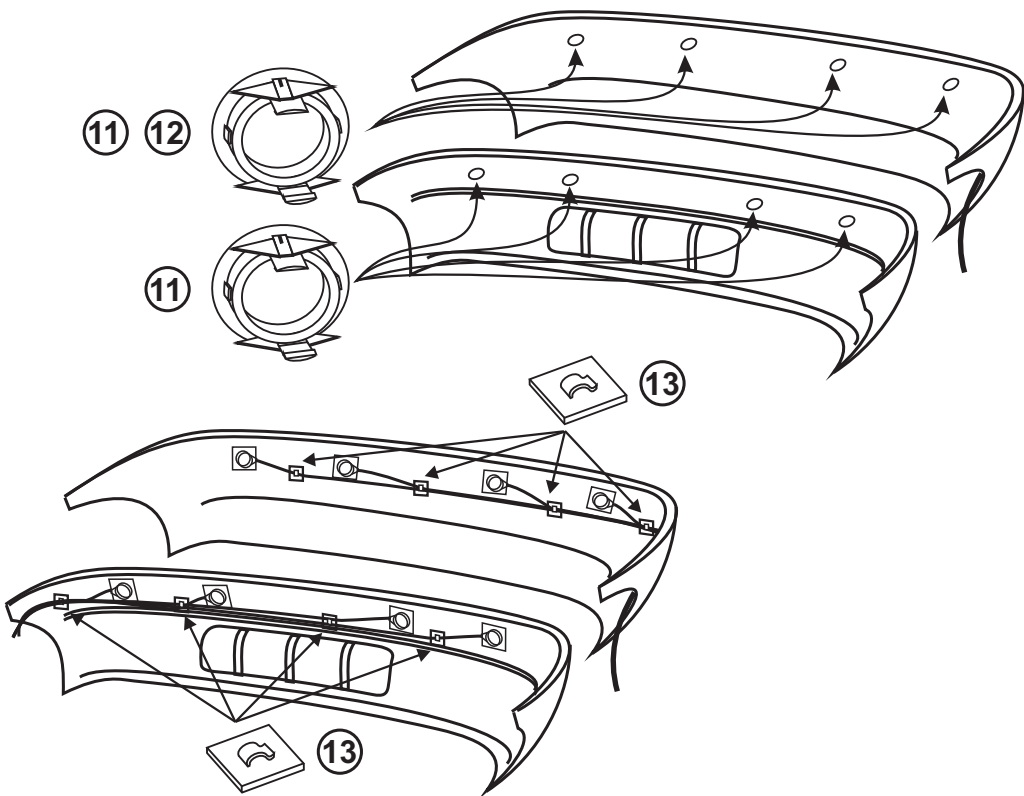

Install the BROWN sensors in the front bumper.
Install the BLUE sensors on the outer edges of the rear bumper.
Install the BLACK sensors on the center of the rear bumper.

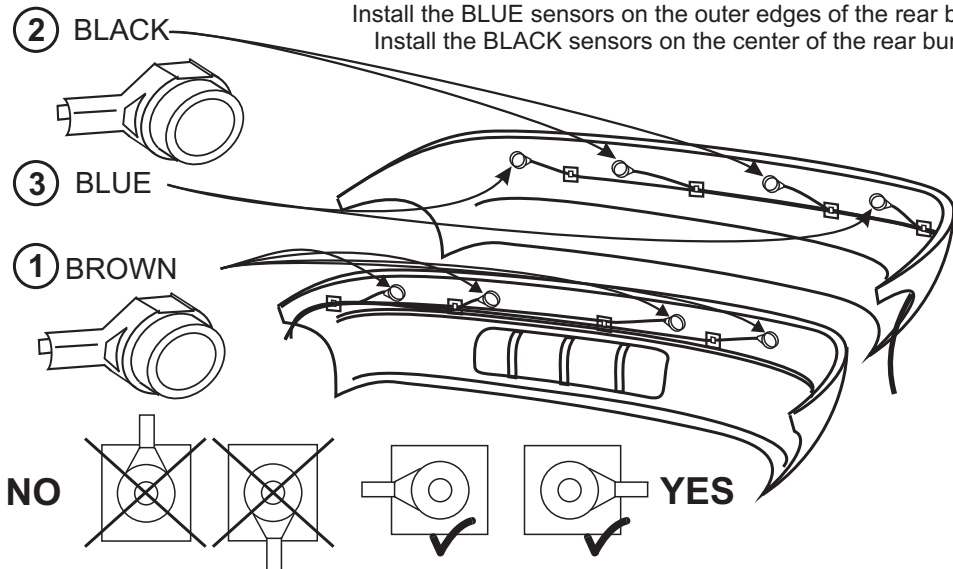

7.0 - CONNECTIONS

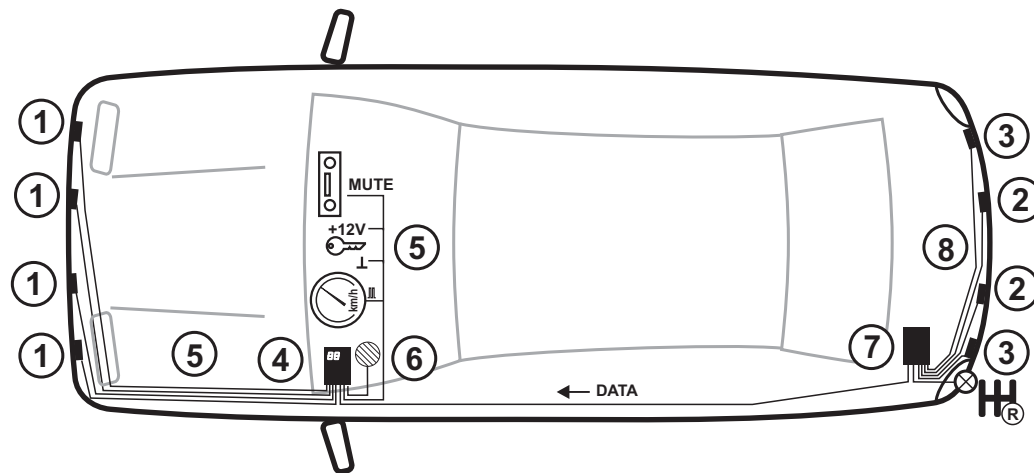

Check the length of the cables before proceeding with the final positioning of the accessories.

- Position the main control unit (4) under the driver side dash and the rear unit (7) in the luggage compartment, both in a dry place, away from eventual water infiltrations and heat sources.
- Run the cables along the bumpers and route them to the respective control units.
- Fix the buzzer (6) inside the vehicle cabin where you can hear the warning signal. Make sure you install it in a dry spot, away from eventual water infiltrations and heat sources.
- Fix the LED push-button (19) where it can be easily reached.
- Plug the LED push-button terminals with the RED, WHITE and BLACK wires to the main control unit wiring harness connector (5), respectively in positions 18, 19 and 7.
- Connect the BLACK-BLUE wire of the control unit wiring harness (5) to the positive under key of the vehicle and the BROWN wire to the metal frame of the vehicle (ground).
- (Optional) connect the BLACK-YELLOW wire to the odometer signal of the vehicle (see chapter "Setting of Parameters" for the programming of the pulses).
- Plug the buzzer terminals with the YELLOW and BLUE wires to the main control unit wiring harness connector (5), respectively in positions 15 and 3.
- (Optional) connect the GREY-RED wire for the "mute" feature to the corresponding wire of the car radio preset for this feature.
- Plug the terminals with the RED-YELLOW and BROWN wires coming from the rear control unit to the main control unit wiring harness connector (5), respectively in positions 17 and 5.
- Connect the BLACK-BLUE wire of the rear unit wiring harness (8) to the positive of the reverse light and the BROWN wire to the metal frame of the vehicle (ground).
- Plug the connectors of the sensors wiring to the respective connectors of the control units (4 and 7).



To switch off on ly the back sensors, ground pin 19 inside the wiring connector (8) of the rear control unit; this connection is useful in case of towing.
Automatic inhibition is also possible if the vehicle and the trailer are electrically connected and an eventual free position is used to ground pin 19 inside the wiring connector (8) of the rear control unit.

8.0 - PROGRAMMING



Only expert users should modify these settings to avoid malfunctions of the parking system.

The unit display (front and rear) will show one of the following indications:

FS

FS: Factory Setting, standard adjustment, "Factory parameters".

CS

CS: Custom Setting, user-chosen adjustment, "Custom Parameters".

To activate the programming procedure proceed as follows:

Press one of the two push-buttons on the control unit and keep it pressed for at least two seconds; the system will activate and enter in the programming mode.

01

Press the left push-button to go to the previous parameter.

Press the right push-button to go to the next parameter.

16

02

When the parameter you want to modify is displayed, press one of the push-buttons and keep it pressed until the display starts to blink; at this point you can modify the parameter.

80

Press the left push-button to decrease the value of the parameter.

Press the right push-button to increase the value of the parameter.

70

90

Press one of the two push-buttons on the control unit and keep it pressed for at least two seconds to register the value.

The display will stop blinking and the selected parameter will be displayed.

03

If no button is pressed within 10 seconds, the system will exit the programming mode.

CS



Press the two push-buttons on the control unit and keep them pressed for more than two seconds to reset all the factory settings (FS).

9.0 - SETTING OF PARAMETERS

9.1 - FRONT UNIT (MAIN UNIT)

Nr.	PARAMETERS	RANGE	SETTING
01	Volume of buzzer	0, 1, 2 (Ref.1)	2
02	Detection range of front central sensors	From 50 to 95 cm	80
03	Detection range of front corner sensors	From 50 to 95 cm	55
04	Detection range of rear central sensors	From 120 to 180 cm (Ref.2)	160
05	Detection range of rear corner sensors	From 50 to 95 cm	55
06	STOP zone of front central sensors	From 35 to 50 cm	35
07	STOP zone of front corner sensors	From 35 to 50 cm	35
08	STOP zone of rear central sensors	From 35 to 70 cm	35
09	STOP zone of rear corner sensors	From 35 to 70 cm	35
11	Number of speed signal pulses	Da 1 to 99	3
12	Delay of front sensors deactivation	0 or from 10 to 60 sec. (Ref.3)	00
13	Delay of rear sensors activation	0, 1 (Ref.4)	0
15	Service display front unit (main unit), system testing	0, 1, 2, 3 (Ref.5)	0
16	Front sensors detection	0,1 (Ref.6)	0
17	Sensitivity of front sensors to detect obstacles	1, 2, 3 (Ref.7)	2

Ref.1: not activated, 1 low, 2 high.

Ref.2: the display having only 2 numbers, the range will be indicated as 20 and 80 instead of 120 and 180.

Ref.3: by setting "00", the system is activated every time ignition is turned on; to deactivate, press the push-button with the LED. Press again, to reengage the sensors.

Ref.4: if your vehicle has an automatic transmission, select "1".

Ref.5: 0 not activated, 1 shows distance from the closest front obstacle, 2 shows distance from the closest rear obstacle (insert reverse gear), 3 shows vehicle speed (in km/h, for programming refer to parameter 11).

Ref.6: 0 only if the car or obstacle is moving, 1 even if the vehicle or obstacle is not moving.

Ref.7: 1 low, 2 standard, 3 high.

9.1 - REAR UNIT

Nr.	PARAMETERS	RANGE	SETTING
10	Suppression of spare wheel indication	0, 1, 2, 3 (Ref.1)	0
17	Sensitivity of rear sensors to detect obstacles	1, 2, 3 (Ref.2)	2

Rif.1: increase the value (setting can be modified from 0= deactivated, to 3) until the system no longer detects the external spare wheel or the tow hitch

Rif.2: 1 low, 2 standard, 3 high.